

# Position Indicating Switches

For Hydraulic and Pneumatic Cylinders

aerospace  
climate control  
electromechanical  
filtration  
fluid & gas handling  
hydraulics  
pneumatics  
process control  
sealing & shielding



ENGINEERING YOUR SUCCESS.

## Our New and Exclusive – *Read.Me Switch*

Position Sensing with a Magnetic Piston and Standard Steel Tube!

Tie rod mounted switch available in both PNP and NPN outputs – See Read.Me pages for details.

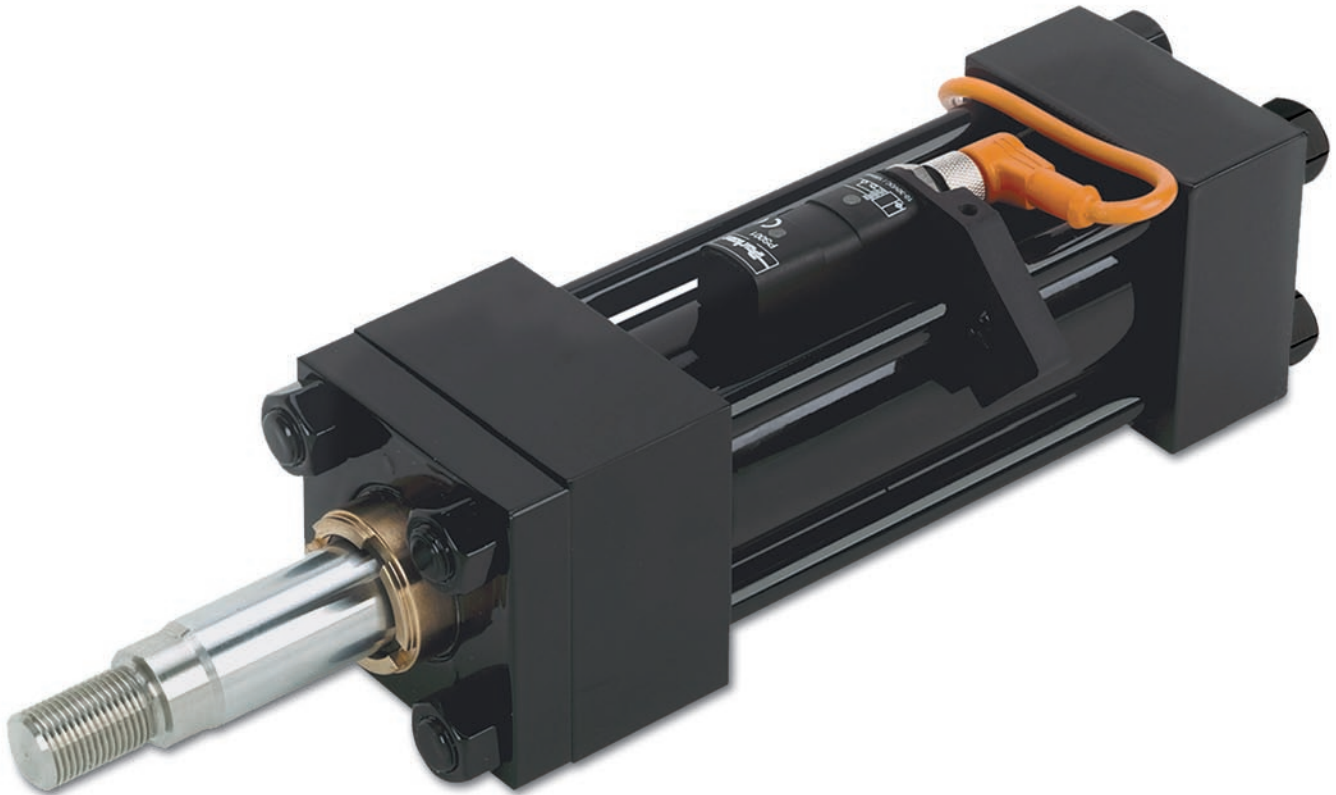

### **Warning**

FAILURE OR IMPROPER SELECTION OR IMPROPER USE OF THE PRODUCTS AND/OR SYSTEMS DESCRIBED HEREIN OR RELATED ITEMS CAN CAUSE DEATH, PERSONAL INJURY AND PROPERTY DAMAGE.

This document and other information from Parker Hannifin Corporation, its subsidiaries and authorized distributors provide product and/or system options for further investigation by users having technical expertise. It is important that you analyze all aspects of your application, including consequences of any failure and review the information concerning the product or system in the current product catalog. Due to the variety of operating conditions and applications for these products or systems, the user, through its own analysis and testing, is solely responsible for making the final selection of the products and systems and assuring that all performance, safety and warning requirements of the application are met.

The product described herein, including without limitation, product features, specifications, designs, availability and pricing, are subject to change by Parker Hannifin Corporation and its subsidiaries at any time without notice.

### **Offer of Sale**

The items described in this document are hereby offered for sale by Parker Hannifin Corporation, its subsidiaries or its authorized distributors. This offer and its acceptance are governed by provisions stated on a separate page of the document entitled 'Offer of Sale'.

**Choose the style that's right for your needs –**

**Tie Rod Mounted Switches –** actuated by a magnetic piston

- Can be positioned at any location along the cylinder to indicate end-of-stroke or mid-stroke locations.
- Allow multiple switches to be installed with numbers only restricted by available tie rod mounting space.
- Are non-intrusive and maintain pressure envelope integrity.
- Available for Series 2H, 3L, and 2A in 1.50" - 4.00" bores.

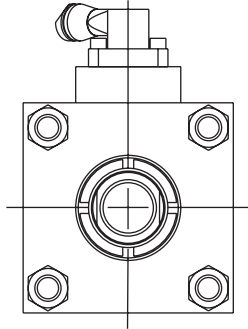

Head or Cap Mounted Switch

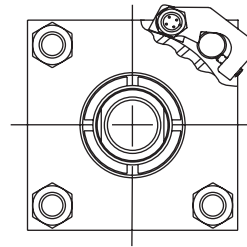

Tie Rod Mounted Switch

**Tie rod mounted switches are lower profile than head and cap mounted styles.**

**Read.Me Switch –**

Innovative sensor exclusive to Parker detects a magnetic piston through a **standard steel tube**. They are an economical alternative to Global Switches for long stroke applications that require a stainless steel tube.

**Global Solid State and Reed Switches –**

Require a non-ferrous tube; stainless steel material in 2H and 3L maintain standard envelope pressure rating; aluminum tube in 3L offers economy with a reduction in envelope pressure rating (see Standard Specifications).

**Head and Cap Mounted Switches**

- Fixed mount design is actuated by proximity (without contact) of cushion sleeve or spear
- Provide an end-of-stroke signal with or without functional cushion
- Available up to 10.00" bore Series 2A and 8.00" bore Series 3L & 3H

**EPS Inductive Switches –**

Are suitable for general industrial as well as automotive applications requiring weld field immunity.

**CLS Magnetic Principal Switches –**

Are contact type switches with no leakage current and are better suited for series wiring, higher load current requirements and have higher temperature resistance.

**Switches mounted on our hydraulic cylinders add value to your machine design**

- Switches and cylinder combine to form a compact package
- Tie rod switches are easily adjustable along cylinder stroke length
- Low profile switches are less prone to mechanical damage

**Magnetic Piston option for 1.50"-4.00" bore Series 2H and 3L cylinders**

- Non-intrusive design eliminates the possibility of oil leakage
- Non-ferrous tube material for conventional solid state and reed switches
- Standard carbon steel tube for Parker Exclusive Read.Me switch

**Series 2H and 3L Cylinder – with Hi-Load magnetic piston**

**Durable polyurethane bi-directional seal** – for positive sealing with no by-pass and long life.

**WearGard™ wear band** – improves resistance to bearing loads and provides support for magnet.

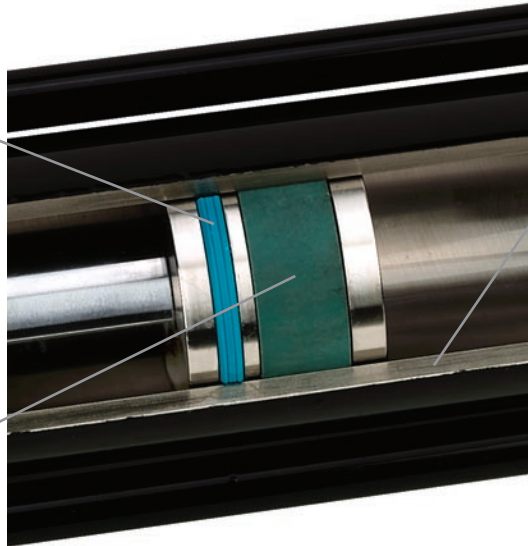

**Cylinder Body** – Standard steel material for Read.Me switch or 316 stainless steel for conventional solid state or reed switches. Aluminum<sup>1</sup> material available in 3L Series.

<sup>1</sup>Reduced pressure ratings apply for aluminum body in 3L series. See Standard Specifications page for ratings by bore size.

**Series 2A Cylinder – with Lipseal Magnetic Piston**

**Piston Lipseals** – are self-compensating to conform to pressure and wear.

**WearGard™ wear band** – improves resistance to bearing loads and provides support for magnet.

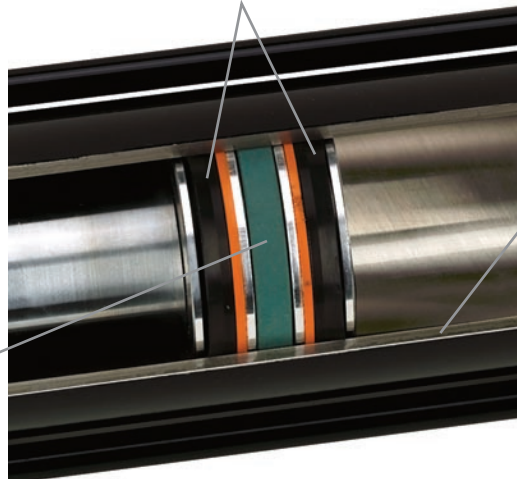

**Cylinder Body** – Standard steel material for Read.Me switch or 316 stainless steel or aluminum for conventional solid state or reed switches.

**Model Ordering Code for Cylinders with Magnetic Piston**

Specify – Piston Code '7' when using Read.Me switches  
– Piston Codes '3' or 'A' when using Reed or Solid State switches

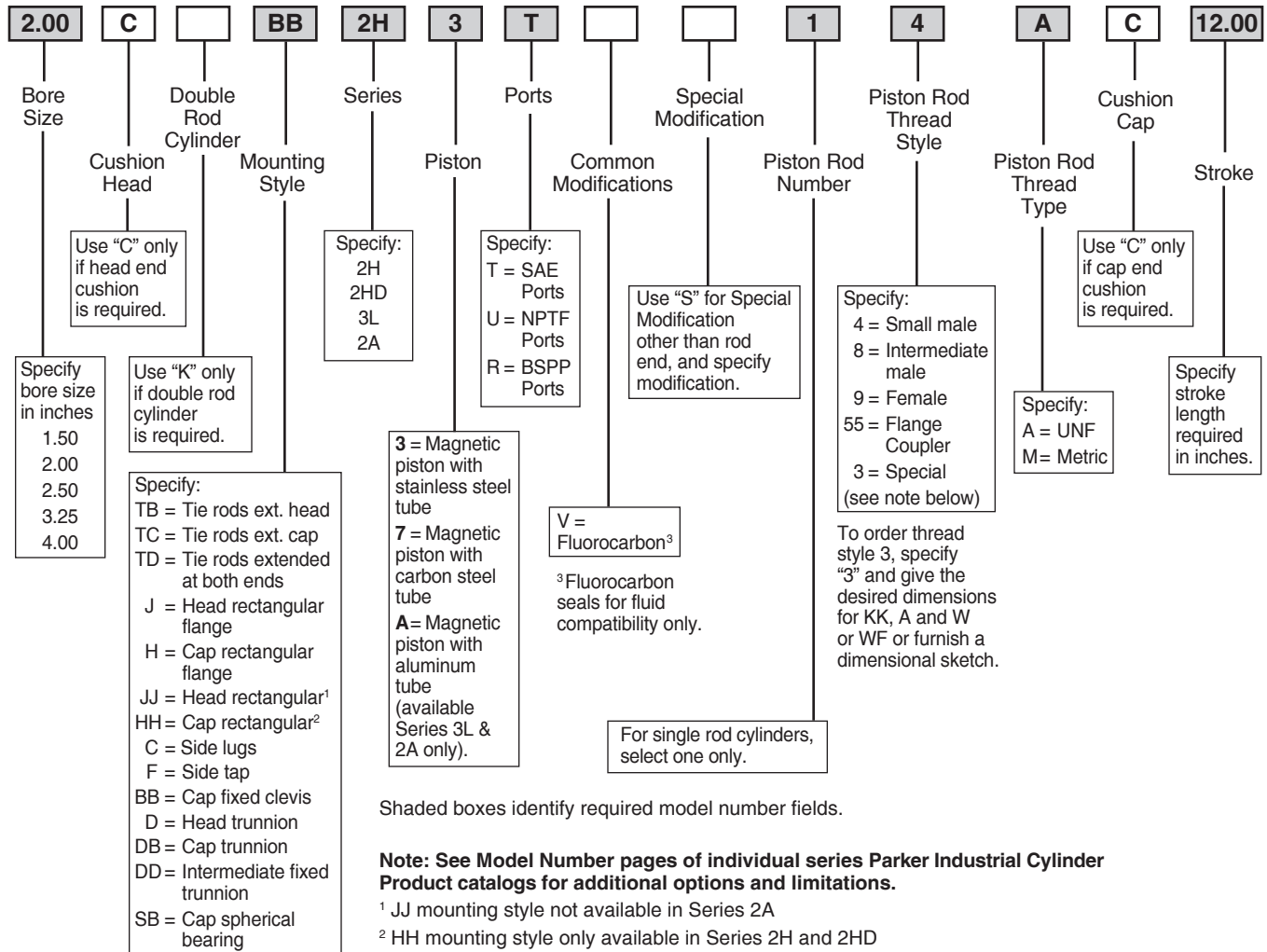

**Standard Specifications**

- Bore sizes – 1.50" to 4.00"
- Strokes – up to 120" (Contact factory for longer strokes)
- Piston rod diameters – 0.625" to 2.500"
- Temperature range – -10°F (-23°C) to +250°F (+121°C) (depending on seal class).
- Switch position may be restricted on mounting style DD
- Working pressure – series and tube material dependent

- 2H & 2HD** – 3000 psi with either carbon steel or stainless steel tube
- 3L** – 1000 psi nominal (dependent on bore size) with either carbon steel or stainless steel tube; reduced pressure with aluminum tube per table.
- 2A** – 250 psi regardless of tube material

Additional product specifications, application information and safety guidelines are available in Parker Industrial Cylinder Product catalogs.

**Maximum Pressure Rating for 3L Cylinder with Aluminum Tube**

Bore Ø	Pressure Rating (psi) <sup>4</sup>
1.50	1300
2.00	1000
2.50	800
3.25	600
4.00	500

<sup>4</sup>When using Series 3L cylinders with aluminum bodies, do not introduce any shock or high inertia loading conditions. Pressure spikes must be avoided.



**Read.Me Switch**

- For magnetic piston sensing through steel tube material
- Cost effective alternative to stainless steel tube for longer strokes
- 4 wire DC connection

**Switch Operation**

The switch detects a change in polarity of the magnetic field as a piston with magnet moves through the cylinder.

**Formatting**

Before the switch is used for the first time, the piston with magnet should be run in and out of the cylinder to format the cylinder tube. The switch will detect the polarity of the residual magnetic field created by the movement of the magnetic piston during formatting.

**Field Direction with Magnetic Piston**

Single rod end cylinders are assembled with the piston magnet's North Pole facing the rod end. As the magnetic piston moves through the cylinder, it creates a stronger field opposite in polarity to the residual magnetism in the cylinder tube. As it moves under the switch, the change in polarity of the magnetic field in the cylinder tube is detected.

**Switch Zone**

Read.Me switching occurs as the piston enters a switching 'zone'. The switching point is highly repeatable, in either direction, under conditions of constant piston speed and operating temperature.

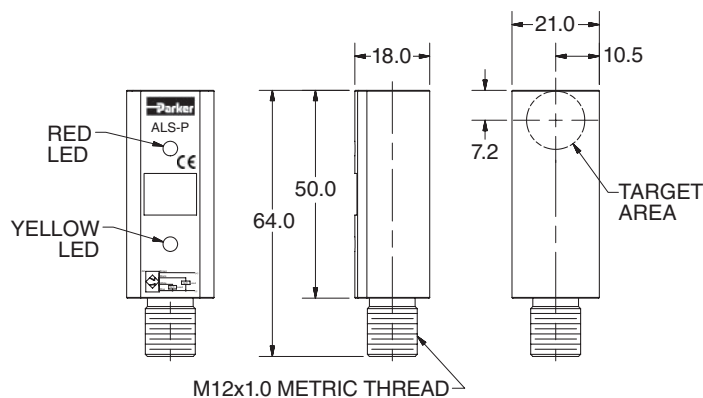

Read.Me switch output states may be influenced by an external magnetic field. Care must be taken to avoid external magnetic field exposure.

- PNP and NPN versions can be wired N.O. or N.C.
- The Read.Me switch is not designed for use with non-ferrous tubes

The switching zone may be up to 50mm wide depending on tube wall thickness and piston speed.

**LED Indicators**

There are two LED's (yellow and red) to indicate that the piston is inside or outside the target zone of the switch. The sequence of the LED's is determined by the orientation of the north pole of the magnet system (rod end side of single rod end cylinders) to the connector.

When the north pole of the magnet system faces the connector, the red LED turns ON when the piston is within the target zone. The yellow LED is on otherwise.

When the south pole of the magnet system faces the connector, the yellow LED turns ON when the piston is within the switching zone. The red LED is ON otherwise.

**Performance**

Parker's Read.Me switches have been designed to operate at a maximum piston speed of 0.5m/s, and a maximum cylinder operating temperature of 85°C.

**Specifications**

<b>Switching Output;</b>	PNP or NPN
<b>Switch Zone<sup>1</sup>:</b>	50mm
<b>Hysteresis<sup>1</sup>:</b>	5mm
<b>Repeatability<sup>1</sup>:</b>	0.5mm
<b>Load Current:</b>	100mA
<b>Leakage Current:</b>	≤ 10µA
<b>Voltage Drop:</b>	≤ 1.5 VDC
<b>Short Circuit and Overload Protection:</b>	Yes
<b>Reverse Polarity Protection:</b>	Yes
<b>Supply Voltage:</b>	10 - 30 VDC
<b>LED(s):</b>	Yes (2)
<b>Current Consumption:</b>	≤ 30 mA
<b>Operating Temperature Range:</b>	-25°C to +85°C (-13°F to +185°F)
<b>Housing Material:</b>	Black Polyamide (PA)

<sup>1</sup>Switch zone, hysteresis, and repeatability based on measurements with a cylinder outer diameter of 46mm, wall thickness of 3mm and piston speed of 0.5m/s.

**Read.Me Switch**

Output & Indicator States when Magnet is within Sensing Range					
Configuration	Switch Location / Connector Orientation	Output State		Indicator	
		Output #1 N.O. (Open/Closed)	Output #2 N.C. (Open/Closed)	Red (On/Off)	Yellow (On/Off)
Case #1	Cap / Rod	Closed	Open	On	Off
	Rod / Cap	Open	Closed	Off	On
Case #2	Cap / Cap	Open	Closed	Off	On
	Rod / Cap	Open	Closed	Off	On
Case #3	Cap / Cap	Open	Closed	Off	On
	Rod / Rod	Closed	Open	On	Off
Case #4	Cap / Rod	Closed	Open	On	Off
	Rod / Rod	Closed	Open	On	Off

Notes: Output states are based on standard magnet orientation of North Pole facing the rod end.  
 The outputs and LED indication will be inverted if the magnet is out of sensor detection range.

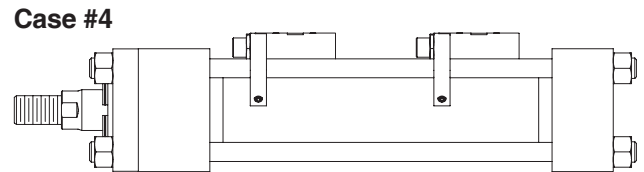
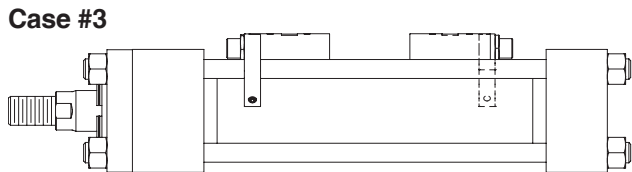
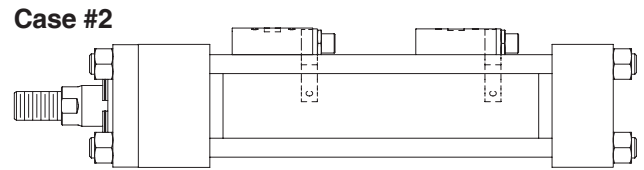
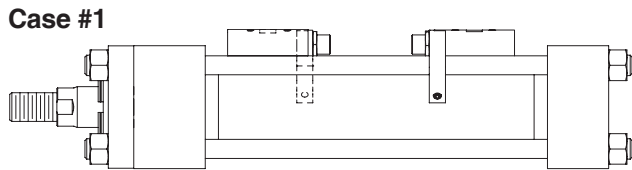

**Read.Me Switch – Wiring Connection**  
**12mm Connector**

**PNP**

Pin	Wire	Function	
		N.C.	N.O.
1	Brown	Operating Voltage (+VDC)	Operating Voltage (+VDC)
4	Black	Not Used	Output Signal (N.O.)
2	White	Output Signal (N.C.)	Not Used
3	Blue	-VDC	-VDC

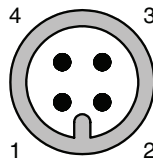

**NPN**

Pin	Wire	Function	
		N.C.	N.O.
1	Brown	(+VDC)	(+VDC)
4	Black	Not Used	Output Signal (N.O.)
2	White	Output Signal (N.C.)	Not Used
3	Blue	Operating Voltage -VDC	Operating Voltage -VDC

**PNP**

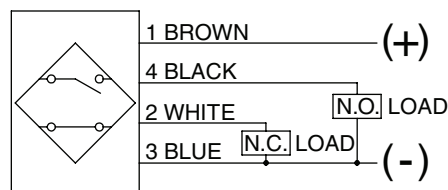

**NPN**

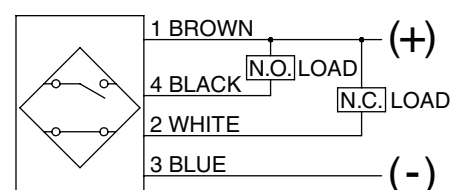

**Read.Me Switch Part Numbers**

All switches are packaged with tie rod mounting bracket and have a 4-pin male M12x1 threaded connector.

Part Number		Switch Bracket Usage
PNP	NPN	
ALS-PL	ALS-NL	Series 3L 1.50 – 4.00 Bore
ALS-PH	ALS-NH	Series 2H 1.50 – 4.00 Bore

Note: Specify piston code '7' in cylinder model number when using Read.Me switches.

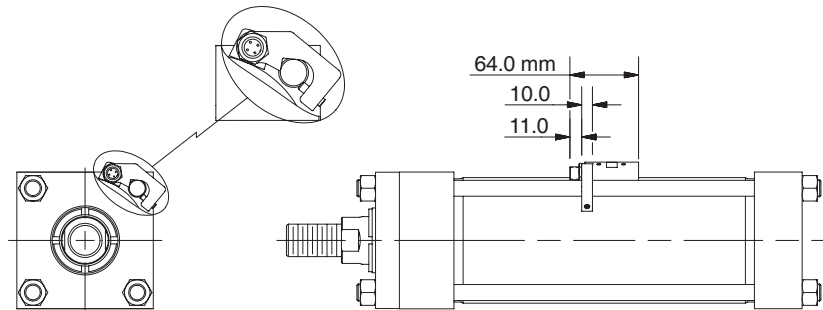

**Minimum Stroke for Read.Me Switch**

Bore Ø	3L	2H
1.50	3.13	3.00
2.00	3.13	3.00
2.50	3.13	2.88
3.25	3.13	2.75
4.00	3.13	2.63

**12mm Cordset for Read.Me & Global Switches**

12mm Cordset with Female Quick Connect

M12 Straight Connector	
Cable Length	Part Number
5 meters	9126487205
2 meters	9126487202

M12 Right Angle Connector	
Cable Length	Part Number
5 meters	9126487305
2 meters	9126487302

A female connector is available for all switches with the male 12mm quick connect option. The cordsets are available with a right angle or straight connector. Cordset part numbers are listed above.

**Cordset Specifications**

- Connector..... Polyvinylchloride (PVC) body material, PVC contact carrier, spacing to VDE 0110 Group C, (250VAC / 300VDC)
- Contacts..... Gold Plated Copper Tin (CuSn), stamped from stock.
- Coupling Method..... Threaded nut: Chrome plated brass.
- Cord Construction ... PVC non-wicking, non-hygroscopic, 250VAC / 300VDC. Cable end is stripped.
- Conductors..... Extra high flex stranding with PVC insulation
- Temperature..... -13°F to 158°F (-25°C to 70°C)
- Protection ..... NEMA 1, 3, 4, 6P and IEC 1P67
- Cable Length..... 6.56 ft (2m) or 16.4 ft (5m)

**Straight Connector**

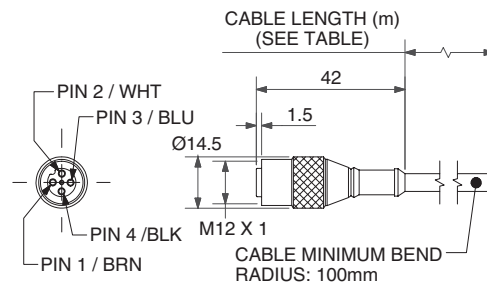

**Right Angle Connector**

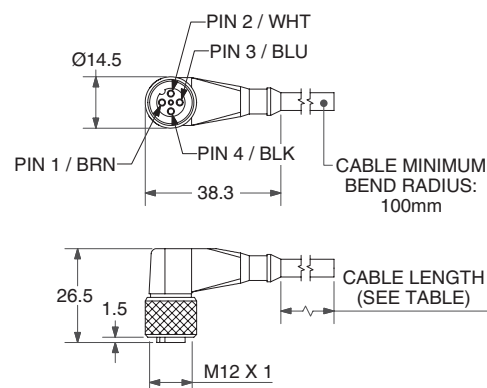

**Notes**

Global Drop-In Solid State Switches  



Wiring	PNP Switch	NPN Switch	PNP Switch ATEX Certified
3m Flying Leads	P8S-GPFLX	P8S-GNFLX	P8S-GPFLX/EX
10m Flying Leads	P8S-GPFTX	P8S-GNFTX	N/A
0.3m Lead with 8mm Connector	P8S-GPSHX	P8S-GNSHX	
0.3m Lead with 12mm Connector	P8S-GPMHX	P8S-GNMHX	
1m Lead with 8mm Connector	P8S-GPSCX	P8S-GNSCX	

Specifications

- Type..... Electronic
- Output Function..... Normally Open
- Switch Output..... PNP/NPN
- Operating Voltage..... 10 - 30VDC
- Continuous Current ..... 100 mA max.
- Response Sensitivity ..... 28 Gauss min.
- Switching Frequency ..... 5 KHz
- Power Consumption ..... 10 mA max.
- Voltage Drop..... 2.5 VDC max.
- Ripple ..... 10% of Operating Voltage
- Hysteresis..... 1.5 mm max.
- Repeatability..... 0.1 mm max.
- EMC..... EN 60 947-5-2
- Short-circuit Protection ..... Yes
- Power-up Pulse Suppression ..... Yes
- Reverse Polarity Protection..... Yes
- Enclosure Rating..... IP 68
- Shock and Vibration Stress ..... 30g, 11 ms, 10 to 55 Hz, 1 mm
- Operating Temperature Range..... -25°C to +75°C (-13°F to 167°F)
- Housing Material ..... PA 12, Black
- Connector Cable..... PVC
- Connector..... PUR cable w/8 or 12 mm connector

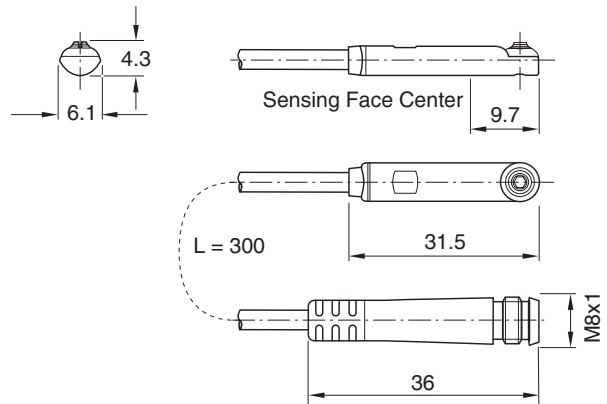

Global solid state switch outputs may be influenced by an external magnetic field. Care must be taken to avoid external magnetic field exposure.

### Solid State Switch – Wiring Connection

#### Flying Lead or 8 mm Connector (shown)

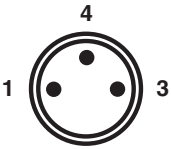

Pin	Wire	Function
1	Brown	Operating Voltage (+VDC)
4	Black	Output signal (N.O.)
3	Blue	-VDC

**PNP**

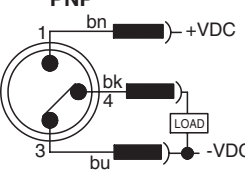

**NPN**

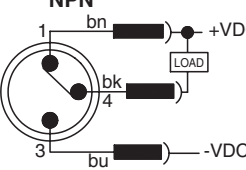

#### 12 mm Connector

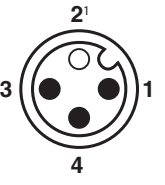

Pin	Wire	Function
1	Brown	Operating Voltage (+VDC)
4	Black	Output Signal (N.O.)
2 <sup>1</sup>	White	Not Used
3	Blue	-VDC

<sup>1</sup>Pin 2 not present.

**PNP**

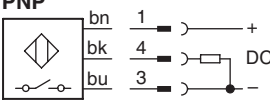

**NPN**

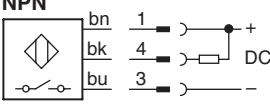

Global Drop-In Reed Switches 

Wiring	Reed Switch
3m Flying Leads	P8S-GRFLX
10m Flying Leads	P8S-GRFTX
0.3m Lead with 8mm Connector	P8S-GRSHX
0.3m Lead with 12mm Connector	P8S-GRMHX
1m Lead with 8mm Connector	P8S-GRSCX

Specifications

Type.....2-Wire Reed  
 Output Function.....Normally Open  
 Operating Voltage.....10 - 120 VAC<sup>1</sup>  
 10 - 30 VDC  
 Switching Power.....6 W/VA  
 Continuous Current.....100 mA max.  
 Response Sensitivity.....30 Gauss min.  
 Switching Frequency.....400 Hz  
 Voltage Drop.....2.5 V max.  
 Ripple.....10% of Operating Voltage  
 Hysteresis.....1.5 mm max.  
 Repeatability.....0.2 mm max.  
 EMC.....EN 60 947-5-2  
 Reverse Polarity Protection.....Yes  
 Enclosure Rating.....IP 68  
 Shock and Vibration Stress.....30g, 11 ms, 10 to 55 Hz, 1 mm  
 Operating Temperature Range.....-25°C to +75°C (-13°F to 167°F)  
 Housing Material.....PA 12, Black  
 Connector Cable.....PVC  
 Connector.....PUR cable with 8 or  
 12 mm connector

Global Reed Switch output may be influenced by external magnetic fields. Care must be taken to avoid external magnetic field exposure. See Parker Industrial Cylinder Catalogs and Cylinder Safety Guide 0800.01-T1 for additional product application information.

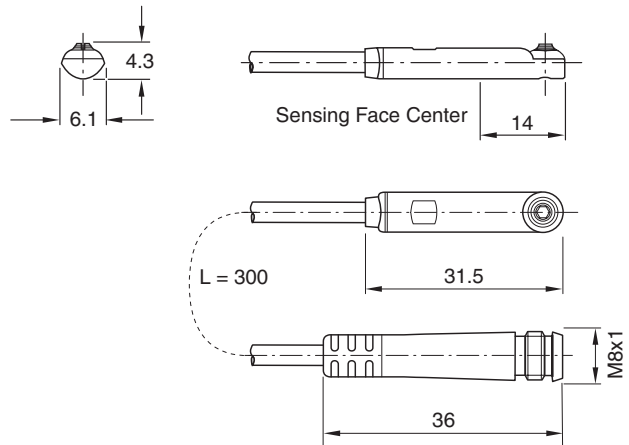

**Reed Switch – Wiring Connection**

**Flying Lead or 8 mm Connector<sup>1</sup>**

Pin	Wire	Function
1	Brown	Operating Voltage (+V)
4	Black	Not Used
3	Blue	Output Signal (-V or Ground)

<sup>1</sup>8mm connector rated for 50 VAC max.

**12 mm Connector**

Pin	Wire	Function
1	Brown	Operating Voltage (+V)
2 <sup>2</sup>	White	Not Used
3	Blue	Output Signal (-V or Ground)
4	Black	Not Used

<sup>2</sup>Pin 2 not present.

**Circuit for Switching Contact Protection (Inductive Loads)**

(Required for proper operation 24V DC)

Put Diode parallel to loads following polarity as shown below.

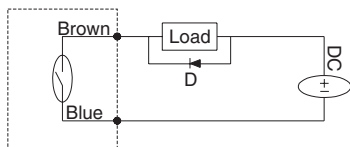

D: Diode: select a Diode with the breakdown voltage and current rating according to the load.

Typical Example—100 Volt, 1 Amp Diode

CR: Relay coil (under 0.5W coil rating)

(Recommended for longer life 120 VAC)

Put a resistor and capacitor in parallel with the load. Select the resistor and capacitor according to the load.

Typical Example:

CR: Relay coil (under 2W coil rating)

R: Resistor 1 KΩ - 5 KΩ, 1/4 W

C: Capacitor 0.1 ΩF, 600 V

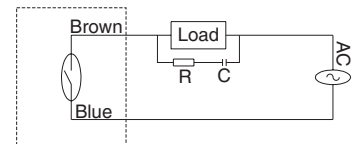

**Caution**

- Use an ammeter to test reed switch current. Testing devices such as incandescent light bulbs may subject the reed sensor to high in-rush loads.
- **NOTE:** When checking an unpowered reed switch for continuity with a digital ohmmeter the resistance reading will change from infinity to a very large resistance (2 M ohm) when the sensor is activated. This is due to the presence of a diode in the reed switch.
- Anti-magnetic shielding is recommended for reed switches exposed to high external RF or magnetic fields.
- The magnetic field strength of the piston magnet is designed to operate with our switches. Other manufacturers' switches may not operate correctly in conjunction with these magnets.
- Use relay coils for reed switch contact protection.

- The operation of some 120 VAC PLC's (especially some older Allen-Bradley PLC's) can overload the reed switch. The switch may fail to release after the piston magnet has passed. This problem may be corrected by the placement of a 700 to 1K OHM resistor between the switch and the PLC input terminal. Consult the manufacturer of the PLC for appropriate circuit.
- Switches with long wire leads (greater than 15 feet) can cause capacitance build-up and sticking will result. Attach a resistor in series with the reed switches (the resistor should be installed as close as possible to the switches). The resistor should be selected such that R (ohms) >E/0.3.
- Global reed switch outputs may be influenced by an external magnetic field. Care must be taken to avoid external magnetic field exposure.

**Tie Rod Bracket Assembly Part Number and Dimensions**

Global switch bracket fits 1.50" - 4.00 bore cylinders. Global switches and bracket assemblies must be ordered separately.

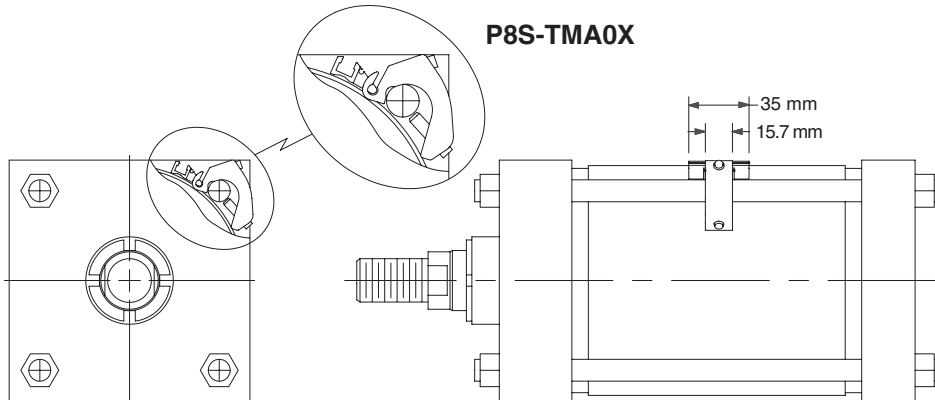

**Cordsets – 8mm Cordset for Global Switches  
8mm Cordset with Female Quick Connect**

A female connector is available for all sensors with the male 8mm quick connect option. The male plug will accept a snap-on or threaded connector. Cordset part numbers are listed below.

Cable Length	Threaded Connector	Snap On Connector
5 meters	086620T005	086620S005
2 meters	086620T002	086620S002

**Cordset Specifications**

- Connector..... Oil resistant polyurethane body material, PA 6 (Nylon) contact carrier, spacings to VDE 0110 Group C, (150 AC/DC)
- Contacts ..... Gold plated beryllium copper, machined from solid stock
- Coupling Method..... Snap-Lock or chrome plated brass nut
- Cord Construction .. Oil resistant black PUR jacket, non-wicking, non-hygroscopic, 300V. Cable end is stripped and tinned.
- Conductors..... Extra high flex stranding, PVC insulation
- Temperature..... -40 to 194°F (-40 to 90°C)
- Protection ..... NEMA 1, 3, 4, 6P and IEC 1P67
- Cable Length..... 6.56 ft (2m) or 16.4 ft (5m)

**Snap-On Straight Connector**

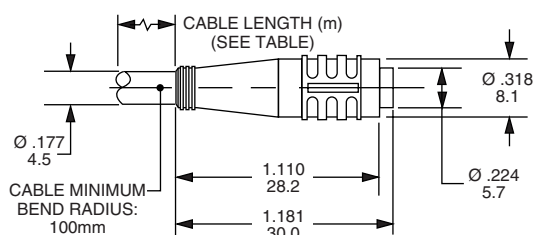

**Threaded Straight Connector**

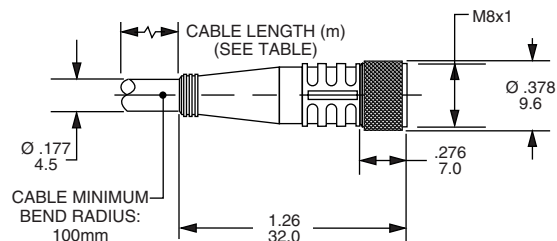

**12mm Cordset for Global Switches**

- See Read.Me Switch Part Number page for 12mm cordsets.

**EPS 7 & 6 Sensors  
Inductive Proximity**

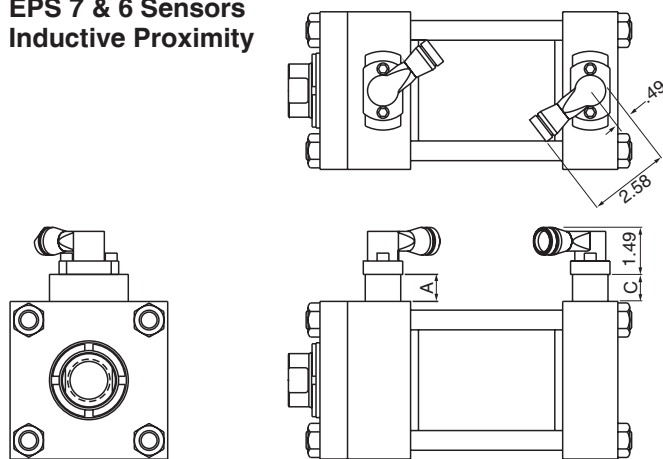

**CLS 1 & 4 Sensors  
Non-Contacting  
Magnetically  
Actuated**

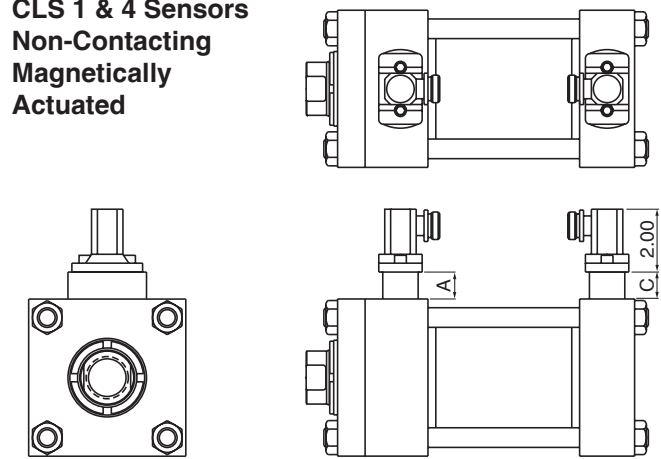

Series	A max.	C max.
2H	.86"	1.75"
3L	1.55"	1.05"
2A	1.55"	1.30"
HMI	1.19"	1.05"

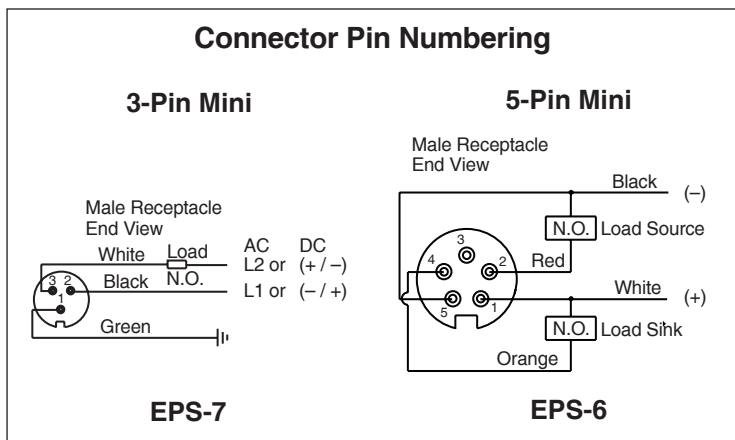

**Series and Parallel Wiring**

When Parker EPS-6 or 7 proximity switches are used as inputs to programmable controllers the preferred practice is to connect each switch to a separate input channel of the PLC. Series or parallel operations may then be accomplished by the internal PLC programming.

Parker EPS-6 or 7 switches may be hard wired for series operation, but the voltage drop through the switches (see specifications) must not reduce the available voltage below what is needed to actuate the load.

Parker EPS-6 or 7 switches may also be hard wired for parallel operation. However, the leakage current of each switch will pass through the load. The total of all leakage currents must not exceed the current required to actuate the load. In most cases, the use of two or more EPS-6 or 7 switches in parallel will require the use of a bypass (shunt) resistor.

**Minimum Stroke**

The minimum stroke for EPS-6 or 7 and CLS-1 or 4 sensors, utilizing standard components, is the cushion sleeve or spear length for the cylinder series in which the sensor is installed. See the individual Industrial Cylinder series catalog for cushion length details. Contact the factory if a shorter stroke is required.

**CLS-2 Threaded Style Switches**

Spacers are not required. Threaded switches can be adjusted for small changes to end of stroke position sensing.

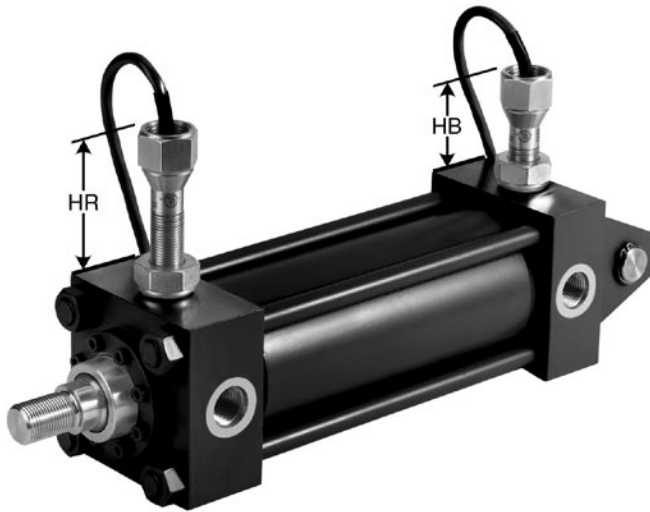

**Switch Height – Series 2H**

Bore	Rod Dia.	HR	HB
1.50	.625	2.56	3.25
	1.000	2.75	
2.00	1.000	2.56	3.00
	1.375	2.75	
2.50	1.000	2.31	2.75
	1.375	2.50	
	1.750	2.75	
3.25	1.375	2.94	2.50
	1.750	3.13	
	2.000	3.31	
4.00	1.750	2.88	2.44
	2.000	3.06	
	2.500	2.44	
5.00	2.000	2.31	3.25
	2.500	2.63	
	3.000	2.88	
	3.500	3.13	
6.00	2.500	2.13	1.44
	3.000	2.38	
	3.500	2.63	
	4.000	2.88	
7.00	3.000	3.38	2.63
	3.500	2.13	
	4.000	2.38	
	4.500	2.63	
	5.000	2.94	
8.00	3.500	3.13	2.25
	4.000	3.38	
	4.500	3.63	
	5.000	2.44	
	5.500	2.75	

As shown in the illustrations below, these switches are magnetically operated. Dual magnets provide a dependable “snap action” for positive position sensing.

In the “Unoperated” position, the magnet assembly is attracted in the opposite direction of the arrow, causing a finely ground stainless steel connecting rod to hold the contacts open.

In the “Operated” position a ferrous part (cushion or piston) enters the sensing area and attracts the magnet assembly which causes the rod to draw the contacts together.

**Switch Height – Series 3L & 2A**

Bore	HR Max.	HB Max	Bore	HR Max.	HB Max
1.50	3.00	2.63	5.00	2.81	3.44
2.00	2.94	2.38	6.00	3.44	3.06
2.50	2.94	3.06	7.00 <sup>1</sup>	3.44	2.56
3.25	3.19	2.81	8.00	3.38	2.06
4.00	3.13	2.44			

<sup>1</sup>7.00 bore not available in Series 3L

**Operating Principle**

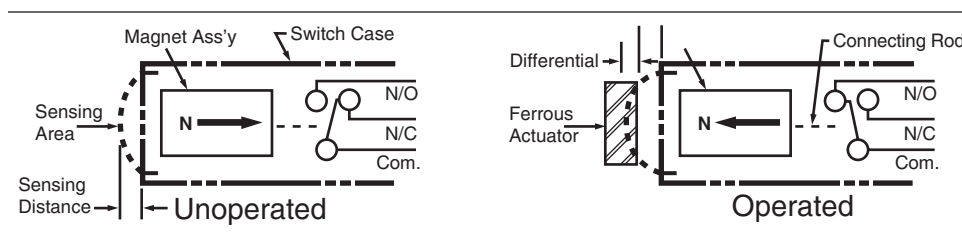

**Sensing gap:** .030" to .060"

**Trip point:** Factory set with piston bottomed out.

**Release point:** Approx. 0.25" piston travel.

Minimum cylinder stroke is .50" on 1.50" & 2.00" bores; and .75" on 2.50" bore and larger.

See the CLS Specification table for additional details.

## Specifications – EPS Limit Switches

Switch Type:	Inductive Proximity	
Style:	EPS-7	EPS-6
Code Designator:	H	D
Description:	Economical, General Purpose, 2 wire device, primarily for AC applications, not suitable for 24 VDC applications. Also for automotive industry applications.	Economical General Purpose, 3 wire, DC sensor, dual output: analog and sourcing.
Supply Voltage:	20 to 250 VAC/DC	10 to 30 VDC
Load Current, min.:	8 mA	NA
Load Current, max.:	300 mA	200 mA
Leakage Current:	1.7 mA max.	10 micro amps max.
Voltage Drop:	7 V, max.	2 VDC max.
Operating Temperature:	-14° to +158° F	-14° to +158° F
Switch Type:	Inductive proximity	Inductive proximity
Part Number:	148897 _ _ _ _	148896 _ _ _ _
4 Digit Part Number Suffix:	Add 4-digit part number suffix to indicate probe length: 0125=1.25", 0206=2.06", 0288=2.875", 0456=4.562"	
Connection:	3 pin mini	5 pin mini
Enclosure Rating:	IEC IP67	IEC IP67
LED Indication:	Yes	Yes
Short Circuit Protection:	Yes	Yes
Weld Field Immunity:	Yes	Yes
Output:	2 wire, Normally Open with leakage current	Dual output: DC Sinking and DC Sourcing, user selectable via wiring
Approvals/Marks:	CE, UL, CSA	CE, UL, CSA
Make/Break Location:	0.125" from end of stroke, typical. Tolerance is +0/- .13"	
Wiring Instructions:	Pin 1: AC Ground (Green) Pin 2: Output (Black) Pin 3: AC Line (White)	Pin 1) +10 to 30 VDC (White) Pin 2) Sourcing Output (Red) Pin 3) Grounded (not connected or required) Pin 4) Sinking Output (Orange) Pin 5) DC Common (Black)
Standard Cable: 6'	0853550006	0859170006
Standard Cable: 12'	0853550012	0859170012
Cable: 6', Right Angle	0875470006	-

**Specifications – CLS Limit Switches**

Switch Type:	Non-Contacting Magnetically Actuated		
<b>Style:</b>	CLS-1	CLS-4	CLS-2
<b>Code Designator:</b>	F	B	G
<b>Description:</b>	For applications where the customer needs NC contacts, zero leakage, zero voltage drop, higher or lower load current than EPS-style.	For applications where the customer needs NC contacts, zero leakage, zero voltage drop, higher or lower load current than EPS-style.	For applications where the customer needs NC contacts, zero leakage, zero voltage drop, higher or lower load current than EPS style. Threaded style permits small adjustability of make/break location.
<b>Supply Voltage:</b>	24 to 240 VAC/DC	24 to 240 VAC/DC	24 to 240 VAC/DC
<b>Load Current, min.:</b>	NA	NA	NA
<b>Load Current, max.:</b>	4 AMPS @ 120 VAC 3 AMPS @ 24 VDC	4 AMPS @ 120 VAC 3 AMPS @ 24 VDC	4 AMPS @ 120 VAC 3 AMPS @ 24 VDC
<b>Leakage Current:</b>	None	None	None
<b>Voltage Drop:</b>	None	None	None
<b>Operating Temperature:</b>	-40° F to +221° F	-40° F to +400° F	-40° F to +221° F
<b>Switch Type:</b>	Non-contacting magnetically actuated	Non-contacting magnetically actuated	Non-contacting magnetically actuated
<b>Part Number:</b>	148275 _ _ _ _	149109 _ _ _ _	117000, 117017, 117034
<b>4 Digit Part Number Suffix:</b>	Add 4-digit part number suffix to indicate probe length: 0125=1.25", 0206=2.06", 0288=2.875", 0456=4.562"		Switch selection is application dependent – Contact Factory
<b>Connection:</b>	3 pin mini	144" PTFE Coated Flying Leads with 1/2" conduit hub	36" Potted-in PVC cable (most sizes also with 1/2" conduit hub)
<b>Enclosure Rating:</b>	NEMA 1, 2, 3, 4, 4X, 5, 6, 6P, 11, 12, 12K, 13	NEMA 1, 2, 3, 4, 4X, 5	NEMA 4, 4X, 6, 6P, 7, 9
<b>LED Indication:</b>	No	No	No
<b>Short Circuit Protection:</b>	No	No	No
<b>Weld Field Immunity:</b>	Yes	Yes	Yes
<b>Output:</b>	SPDT (Single Pole Double Throw), Normally Open/Normally Closed, Form C	SPDT (Single Pole Double Throw), Normally Open/Normally Closed, Form C	SPDT (Single Pole Double Throw), Normally Open/Normally Closed, Form C
<b>Approvals/Marks:</b>	UL or CSA†	UL or CSA†	UL or CSA†
<b>Make/Break Location:</b>	0.125" from end of stroke, typical. Tolerance is +0/- .13"		
<b>Wiring Instructions:</b>	Pin 1: Common (Green) Pin 2: Normally Closed (Black) Pin 3: Normally Open (White)	Common (Black) Normally Open (Blue) Normally Closed (Red)	Common (Black) Normally Open (Blue) Normally Closed (Red)
<b>Standard Cable: 6'</b>	085355-0006	–	–
<b>Standard Cable: 12'</b>	085355-0012	–	–
<b>Cable: 6', Right Angle</b>	087547-0006	–	–

†CSA available upon request – consult factory



## How to Order EPS & CLS Limit Switches

Parker EPS & CLS proximity switches may be ordered on Series 2A, 3L, 2H, 3H and HMI cylinders as follows:

- 1) Complete the basic model number
- 2) Place an "S" in the model number to denote switches and/or special features.

### How to Specify EPS & CLS Switches

- 5) Specify letter prefix "H" for EPS-7, "D" for EPS-6, "F" for CLS-1, "B" for CLS-4, or "G" for CLS-2, then fill in the four blanks specifying port location, switch orientation and actuation point for both head and cap. If only one switch is used, place "XXXX" in the unused blanks.

## Hydraulic and Pneumatic Cylinders Position Indicating Switches

- 3) Mounting styles D, DB, JJ, J, and H should be used with caution because of possible mounting interferences.
- 4) Special modifications to cylinders other than switches must have a written description.

Example = H13CGG-XXXX denotes a switch on the head end only, EPS-7.

Example = XXXX-B42BGG denotes a switch on the cap end only, CLS-4

### Head End

H	1	3	A	GG
Specify: "H" = EPS-7 "D" = EPS-6 "F" = CLS-1 <sup>1</sup> "B" = CLS-4 <sup>1</sup> "G" = CLS-2 "N" = Prepared for EPS or CLS Bolt-on Switch "T" = Prepared for CLS-2 Threaded Switch	Port Location See Figure 1.	Switch Location See Figure 1.	Switch Orientation See Figure 2 for EPS-7 and EPS-6 only.	Actuation Point GG = End of Stroke.

### Cap End

4	2	B	GG
Port Location See Figure 1.	Switch Location See Figure 1.	Switch Orientation See Figure 2 for EPS-7 and EPS-6 only.	Actuation Point GG = End of Stroke.

<sup>1</sup>CLS-1 and CLS-4 switches are not available on the head end of 1.50" bore with 1.000" rod and 2.00" bore with 1.375" rod.  
Note: All specified switch and port locations are as seen from rod end of cylinder.

Figure 1

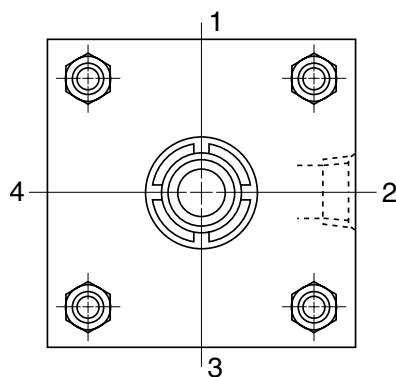
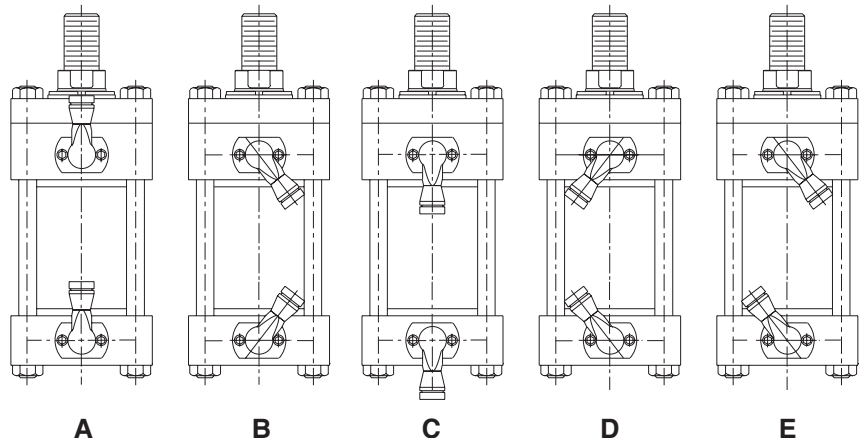

Figure 2



## Offer of Sale

The items described in this document and other documents or descriptions provided by Parker Hannifin Corporation, its subsidiaries and Divisions ("Company") and its authorized distributors, are hereby offered for sale at prices to be established by the Company, its subsidiaries and its authorized distributors. This offer and its acceptance by any customer ("Buyer") shall be governed by all of the following Terms and Conditions. Buyer's order for any such item, when communicated to the Company, its subsidiary or an authorized distributor ("Seller") verbally or in writing, shall constitute acceptance of this offer.

**1. Terms and Conditions of Sale:** All descriptions, quotations, proposals, offers, acknowledgments, acceptances and sales of Seller's products are subject to and shall be governed exclusively by the terms and conditions stated herein. Buyer's acceptance of any offer to sell is limited to these terms and conditions. Any terms or conditions in addition to, or inconsistent with those stated herein, proposed by Buyer in any acceptance of an offer by Seller, are hereby objected to. No such additional, different or inconsistent terms and conditions shall become part of the contract between Buyer and Seller unless expressly accepted in writing by Seller. Seller's acceptance of any offer to purchase by Buyer is expressly conditional upon Buyer's assent to all the terms and conditions stated herein, including any terms in addition to, or inconsistent with those contained in Buyer's offer. Acceptance of Seller's products shall in all events constitute such assent.

**2. Payment:** Payment shall be made by Buyer net 30 days from the date of delivery of the items purchased hereunder. Amounts not timely paid shall bear interest at the maximum rate permitted by law for each month or portion thereof that the Buyer is late in making payment. Any claims by Buyer for omissions or shortages in a shipment shall be waived unless Seller receives notice thereof within 30 days after Buyer's receipt of the shipment.

**3. Delivery:** Unless otherwise provided on the face hereof, delivery shall be made F.O.B. Seller's plant. Regardless of the method of delivery, however, risk of loss shall pass to Buyer upon Seller's delivery to a carrier. Any delivery dates shown are approximate only and Seller shall have no liability for any delays in delivery.

**4. Warranty:** Seller warrants that the items sold hereunder shall be free from defects in material or workmanship for a period of 18 months from date of shipment from the Company. **THIS WARRANTY COMPRISES THE SOLE AND ENTIRE WARRANTY PERTAINING TO ITEMS PROVIDED HEREUNDER. SELLER MAKES NO OTHER WARRANTY, GUARANTEE, OR REPRESENTATION OF ANY KIND WHATSOEVER. ALL OTHER WARRANTIES, INCLUDING BUT NOT LIMITED TO, MERCHANTABILITY AND FITNESS FOR PURPOSE, WHETHER EXPRESS, IMPLIED, OR ARISING BY OPERATION OF LAW, TRADE USAGE, OR COURSE OF DEALING ARE HEREBY DISCLAIMED.**

**NOTWITHSTANDING THE FOREGOING, THERE ARE NO WARRANTIES WHATSOEVER ON ITEMS BUILT OR ACQUIRED WHOLLY OR PARTIALLY, TO BUYER'S DESIGN OR SPECIFICATIONS.**

**5. Limitation of Remedy: SELLER'S LIABILITY ARISING FROM OR IN ANY WAY CONNECTED WITH THE ITEMS SOLD OR THIS CONTRACT SHALL BE LIMITED EXCLUSIVELY TO REPAIR OR REPLACEMENT OF THE ITEMS SOLD OR REFUND OF THE PURCHASE PRICE PAID BY BUYER, AT SELLER'S SOLE OPTION. IN NO EVENT SHALL SELLER BE LIABLE FOR ANY INCIDENTAL, CONSEQUENTIAL OR SPECIAL DAMAGES OF ANY KIND OR NATURE WHATSOEVER, INCLUDING BUT NOT LIMITED TO LOST PROFITS ARISING FROM OR IN ANY WAY CONNECTED WITH THIS AGREEMENT OR ITEMS SOLD HEREUNDER, WHETHER ALLEGED TO ARISE FROM BREACH OF CONTRACT, EXPRESS OR IMPLIED WARRANTY, OR IN TORT, INCLUDING WITHOUT LIMITATION, NEGLIGENCE, FAILURE TO WARN OR STRICT LIABILITY.**

**6. Changes, Reschedules and Cancellations:** Buyer may request to modify the designs or specifications for the items sold hereunder as well as the quantities and delivery dates thereof, or may request to cancel all or part of this order, however, no such requested modification or cancellation shall become part of the contract between Buyer and Seller unless accepted by Seller in a written amendment to this Agreement. Acceptance of any such requested modification or cancellation shall be at Seller's discretion, and shall be upon such terms and conditions as Seller may require.

**7. Special Tooling:** A tooling charge may be imposed for any special tooling, including without limitations, dies, fixtures, molds and patterns, acquired to manufacture items sold pursuant to this contract. Such special tooling shall be and remain Seller's property notwithstanding payment of any charges by Buyer. In no event will Buyer acquire any interest in apparatus belonging to Seller which is utilized in the manufacture of the items sold hereunder, even if such apparatus has been specially converted or adapted for such manufacture and notwithstanding any charges paid by Buyer. Unless otherwise agreed, Seller shall have the right to alter, discard or otherwise dispose of any special tooling or other property in its sole discretion at any time.

**8. Buyer's Property:** Any designs, tools, patterns, materials, drawings, confidential information or equipment furnished by Buyer, or any other items which become Buyer's property, may be considered obsolete and may be destroyed by Seller after two (2) consecutive years have elapsed without Buyer placing an order for the items which are manufactured using such property. Seller shall not be responsible for any loss or damage to such property while it is in Seller's possession or control.

**9. Taxes:** Unless otherwise indicated on the face hereof, all prices and charges are exclusive of excise, sales, use, property, occupational or like taxes which may be imposed by any taxing authority upon the manufacture, sale or delivery of the items sold hereunder. If any such taxes must be paid by Seller or if Seller is liable for the collection of such tax, the amount thereof shall be in addition to the amounts for the items sold. Buyer agrees to pay all such taxes or to reimburse Seller therefore upon receipt of its invoice. If Buyer claims exemption from any sales, use or other tax imposed by any taxing authority, Buyer shall save Seller harmless from and against any such tax, together with any interest or penalties thereon which may be assessed if the items are held to be taxable.

**10. Indemnity For Infringement of Intellectual Property Rights:** Seller shall have no liability for infringement of any patents, trademarks, copyrights, trade dress, trade secrets or similar rights except as provided in this Part 10. Seller will defend and indemnify Buyer against allegations of infringement of U.S. patents, U.S. trademarks, copyrights, trade dress and trade secrets (hereinafter "Intellectual Property Rights"). Seller will defend at its expense and will pay the cost of any settlement or damages awarded in an action brought against Buyer based on an allegation that an item sold pursuant to this contract infringes the Intellectual Property Rights of a third party. Seller's obligation to defend and indemnify Buyer is contingent on Buyer notifying Seller within ten (10) days after Buyer becomes aware of such allegations of infringement, and Seller having sole control over the defense of any allegations or actions including all negotiations for settlement or compromise. If an item sold hereunder is subject to a claim that it infringes the Intellectual Property Rights of a third party, Seller may, at its sole expense and option, procure for Buyer the right to continue using said item, replace or modify said item so as to make it noninfringing, or offer to accept return of said item and return the purchase price less a reasonable allowance for depreciation. Notwithstanding the foregoing, Seller shall have no liability for claims of infringement based on information provided by Buyer, or directed to items delivered hereunder for which the designs are specified in whole or part by Buyer, or infringements resulting from the modification, combination or use in a system of any item sold hereunder. The foregoing provisions of this Part 10 shall constitute Seller's sole and exclusive liability and Buyer's sole and exclusive remedy for infringement of Intellectual Property Rights.

If a claim is based on information provided by Buyer or if the design for an item delivered hereunder is specified in whole or in part by Buyer, Buyer shall defend and indemnify Seller for all costs, expenses or judgements resulting from any claim that such item infringes any patent, trademark, copyright, trade dress, trade secret or any similar right.

**11. Force Majeure:** Seller does not assume the risk of and shall not be liable for delay or failure to perform any of Seller's obligations by reason of circumstances beyond the reasonable control of Seller (hereinafter "Events of Force Majeure"). Events of Force Majeure shall include without limitation, accidents, acts of God, strikes or labor disputes, acts, laws, rules or regulations of any government or government agency, fires, floods, delays or failures in delivery of carriers or suppliers, shortages of materials and any other cause beyond Seller's control.

**12. Entire Agreement/Governing Law:** The terms and conditions set forth herein, together with any amendments, modifications and any different terms or conditions expressly accepted by Seller in writing, shall constitute the entire Agreement concerning the items sold, and there are no oral or other representations or agreements which pertain thereto. This Agreement shall be governed in all respects by the law of the State of Ohio. No actions arising out of sale of the items sold hereunder or this Agreement may be brought by either party more than two (2) years after the cause of action accrues.



Parker Hannifin Corporation  
**Cylinder Division**  
500 South Wolf Road  
Des Plaines, IL 60016 USA  
phone (847) 298-2400  
fax (800) 892-1008  
[www.parker.com/cylinder](http://www.parker.com/cylinder)

Parker Hannifin Corporation  
Motion and Control Division  
160 Chisholm Drive  
Milton, ON Canada L9T 3G9  
direct (905) 693-3000  
fax (905) 876-1958  
[www.parker.com](http://www.parker.com)

